

Clanbro® POWER WASHER



3600PSI DIESEL POWER WASHER

MODEL NO: DLS360

PART NO: 7330376

OPERATION & MAINTENANCE INSTRUCTIONS

UK
CA | CE



ORIGINAL INSTRUCTIONS

DL 0124

INTRODUCTION

Thank you for purchasing this CLARKE Diesel Power Washer.

Before attempting to use this product, please read this manual thoroughly and follow the instructions carefully. In doing so you will ensure the safety of yourself and that of others around you, and you can look forward to your purchase giving you long and satisfactory service.

GUARANTEE

This product is guaranteed against faulty manufacture for a period of 12 months from the date of purchase. Please keep your receipt which will be required as proof of purchase.

This guarantee is invalid if the product is found to have been abused or tampered with in any way, or not used for the purpose for which it was intended.

Faulty goods should be returned to their place of purchase, no product can be returned to us without prior permission.

This guarantee does not effect your statutory rights.

UNPACKING

Unpack your power washer and check to ensure the following items are present. Contact your CLARKE dealer immediately if any parts are missing or damaged.

1 x Diesel Power Washer	1 x Pressure Washer Hose
1 x Delivery Hose c/w Fittings	1 x Hose/Lance Storage Bracket
1 x Suction Hose c/w Fittings	4 x Wheel/Pneumatic Tyres
1 x Detergent Hose c/w Fittings	4 x Wheel Axles and Fittings
1 x Lance/Nozzle Assembly	1 x Engine Manual
1 x Gun Assembly	1 x Tool Kit: Multi-Head Screwdriver, 10/12 Spanner, 14/17 Spanner

GENERAL SAFETY RULES



WARNING: WATER AT HIGH PRESSURE CAN BE DANGEROUS AND CAN CAUSE DAMAGE TO PERSONS OR PROPERTY IF THE OPERATOR IS CARELESS. NEVER ALLOW ANYONE TO OPERATE THIS EQUIPMENT UNLESS THEY ARE THOROUGHLY RELIABLE, AND FAMILIAR WITH THE SAFETY PRECAUTIONS.

1. **DO NOT** point the spray at other people, animals, electrical equipment or the machine itself.
2. **DO NOT** hold your finger over the high pressure nozzle.
3. **DO NOT** let children or untrained personnel use this machine.
4. **DO NOT** operate the machine with any of the covers removed.
5. **DO NOT** try to repair this machine. Always refer to your CLARKE service department for all repairs.
6. **DO NOT** supply any liquid other than water to the water inlet.
7. **DO NOT** use the detergent pickup facility to introduce flammable liquids/ solvents, e.g. paint thinners, petrol, oil, as there is a risk of explosion.
8. **ALWAYS** release the remaining pressure in the system; turn off the water supply and operate the trigger before you remove hoses or accessories.
9. **ALWAYS** keep the machine dry and away from the water spray.
10. **ALWAYS** use protective clothing and safety goggles. Loose particles and other items can be propelled at high speed by the water spray.
11. **ALWAYS** hold the gun securely & expect it to 'kick' when you pull the trigger.
12. **ALWAYS** respect the requirements of the local water company. Pressure washers may only be connected to the mains water supply if a system separator (also known as a backflow preventer) is installed in the supply hose.
13. **ALWAYS** disconnect from the water supply, and make sure that you drain the system when not in use. Keep in a cool dry location.
14. **ONLY** use detergents that are suitable for pressure washers, we recommend that you use CLARKE Traffic Film Remover or CLARKE Wash and Wax (available from your CLARKE dealer).
15. **WARNING:** high pressure water jets can be dangerous, the jet must not be directed at a person or anything that they are wearing.
16. **WARNING:** high pressure hoses, fittings and couplings are important for the safety of the machine. Use only hoses, fittings and couplings recommended by the manufacturer.
17. **WARNING:** water that passes through a system separator (also known as a backflow preventer) is not safe to drink.
18. **DO NOT** use the pressure washer if there is damage to the inlet/outlet hose or the machine.

SAFETY SYMBOLS

	ALWAYS: Read this manual and make sure that all warnings and instructions are clear before use.		ALWAYS: Wear eye protection
	ALWAYS: Use protective gloves, footwear and waterproof clothing.		ALWAYS: Wear ear protection.
	DANGER: Risk to breathing. Engine exhaust fumes. For outdoor use only.		WARNING: Risk of severe injury. DO NOT directly discharge stream at persons or animals. Keep clear of nozzle.
	WARNING: Risk of chemical burn. NEVER spray corrosive or toxic chemicals. Use only cleaners formulated for power washers.		WARNING: Risk of electrocution. NEVER direct the spray toward any electrical device or electrical outlet.
	DANGER: Risk of fire or explosion. DO NOT spray flammable liquids.		WARNING: Risk of unsafe operation. Gun kicks back. Hold with both hands.
	WARNING: Risk of hot surfaces. Avoid contact with hot engine exhaust components. DO NOT allow hoses to contact the engine muffler during or after use.		

SPECIFICATIONS

Model	DLS360
Engine	
Engine Model	G390FD
Power (HP)	9hp/6.6kW/3600rpm
Engine type	Diesel
Starting systems	Key & Recoil
Battery	12V, 20AH
Fuel Tank Capacity (L)	5.5
Water supply	
Max. feed temperature	30°C
Min. feed volume (l/min.)	17
Water Inlet Pressure	3-6 Bar
Water Pump	
Maximum pressure	248 Bar/3600 Psi
Working pressure	228 Bar/3300 Psi
Max. water flow (l/min.)	17 (Mains supply) 15.3 (Barrel supply)
Measured sound power level LWA dB	93.62
Guaranteed sound power level LWA dB	107.53
Vibration - Main Handle	2.073m/s ²
Dimensions	
Length/Width/Height - Handle Raised (mm)	900/1610/1100
Weight (kg)	96

GENERAL OVERVIEW

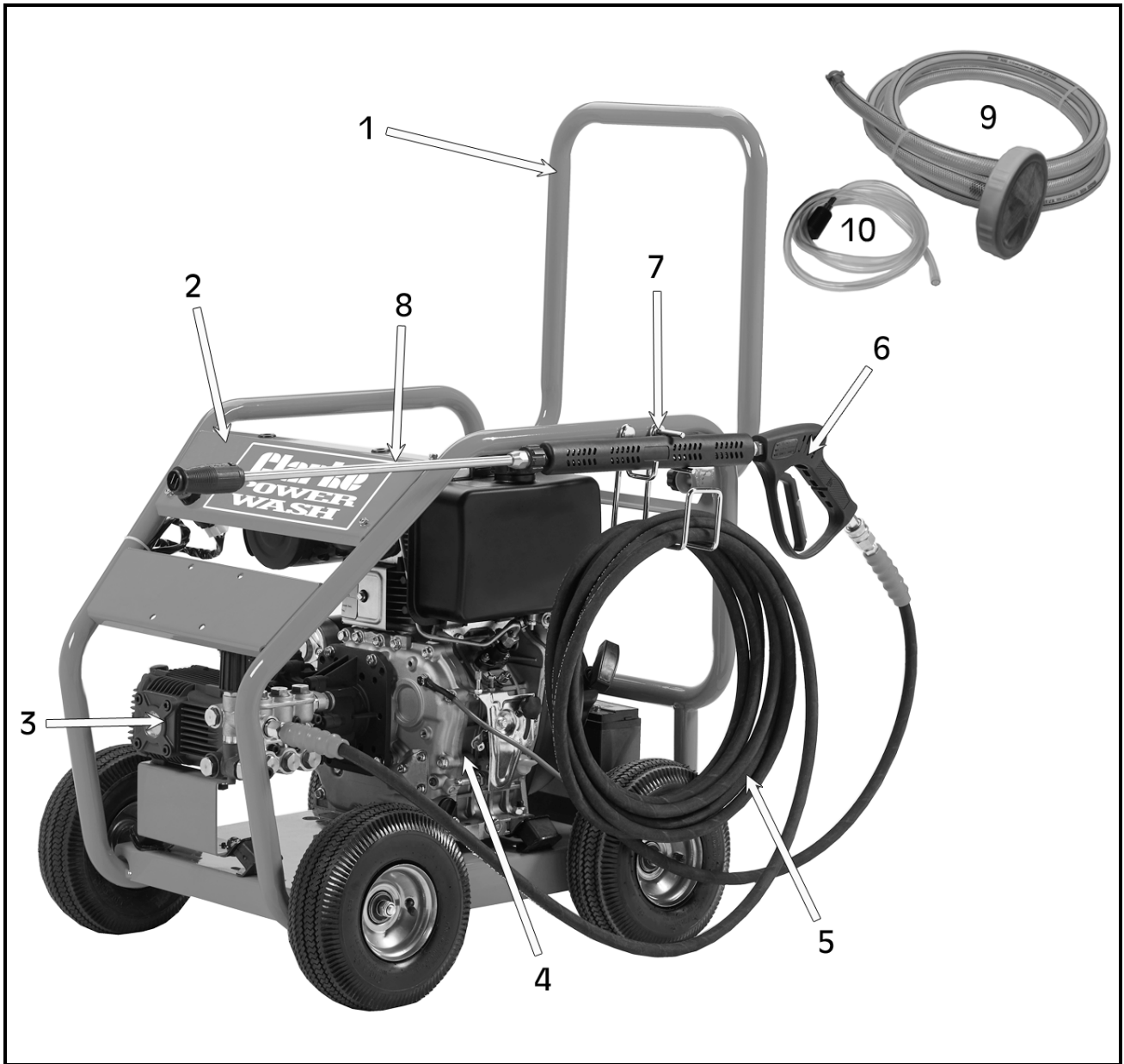

NO	DESCRIPTION	NO	DESCRIPTION
1	Foldable Handle	7	Wand/Lance & Hose Bracket
2	Frame	8	Spray Wand/Lance
3	Pump	9	Water Inlet Hose with Filter
4	Engine	10	Detergent Hose
5	10m High Pressure Hose	11	Tool Kit: Multi-Head Screwdriver, 10/12 Spanner, 14/17 Spanner (Not Shown)
6	Gun		

PARTS IDENTIFICATION AND FEATURES

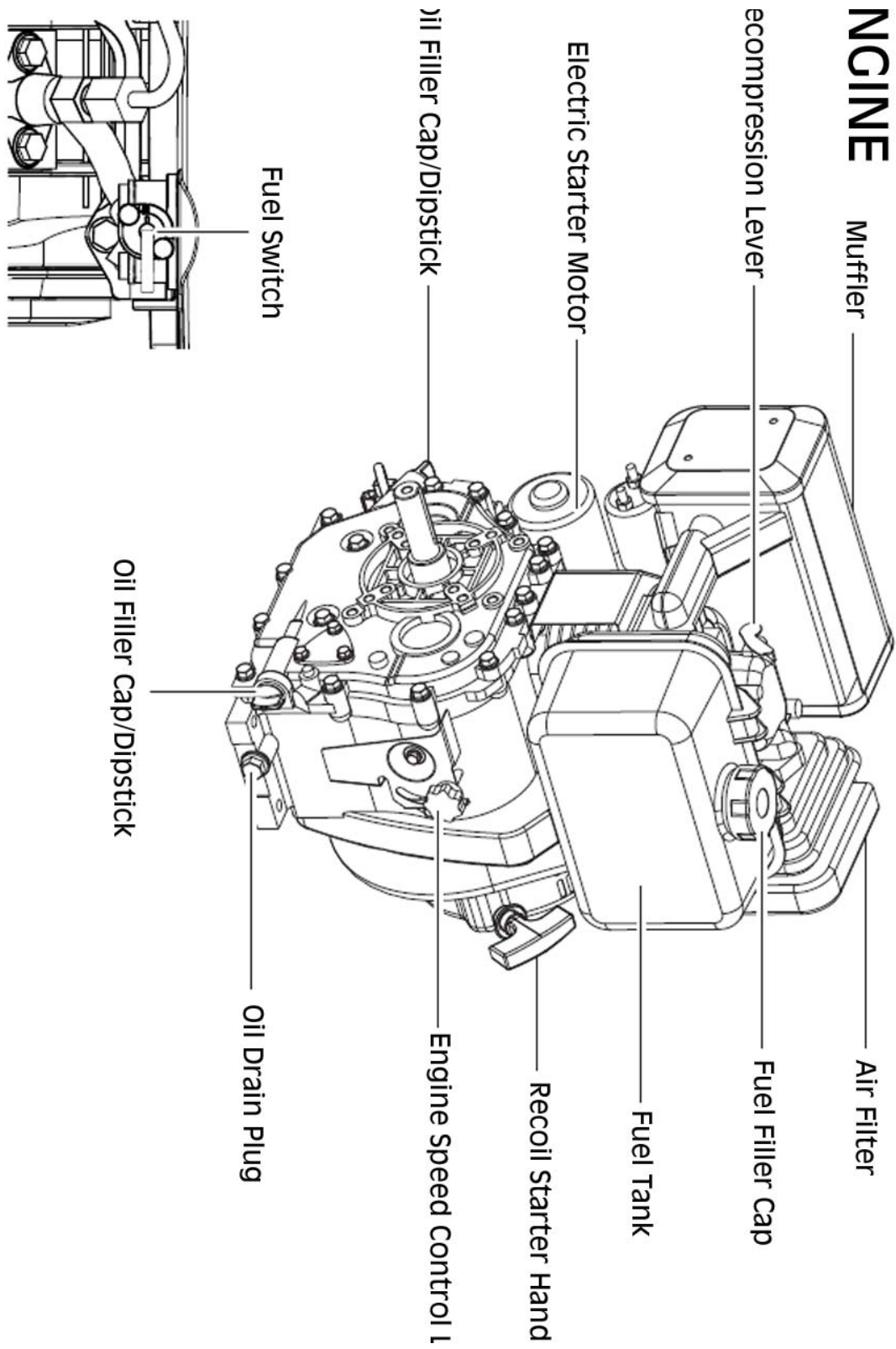

PARTS IDENTIFICATION AND FEATURES

PUMP

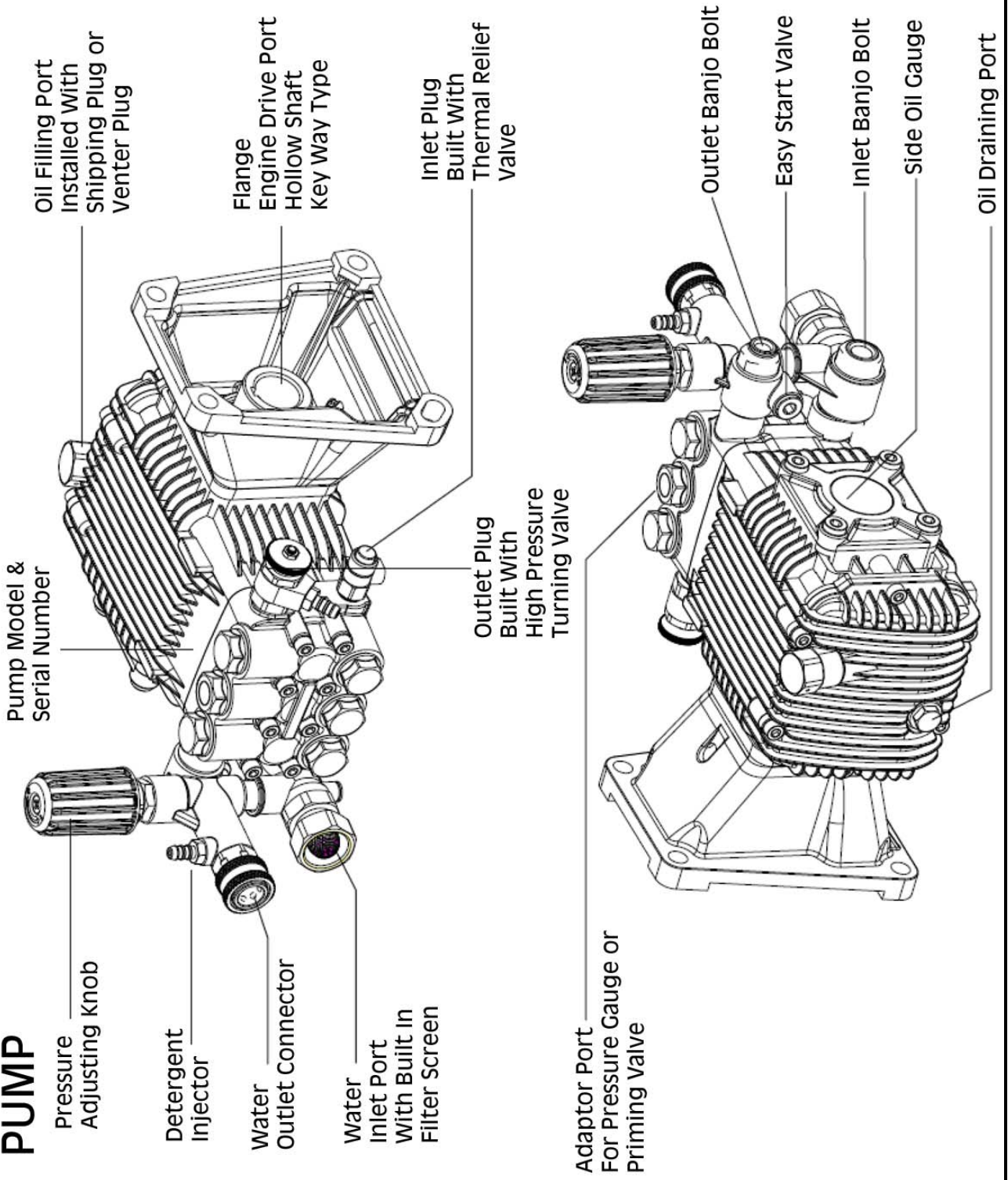

PARTS IDENTIFICATION AND FEATURES

Gear Reduction Box

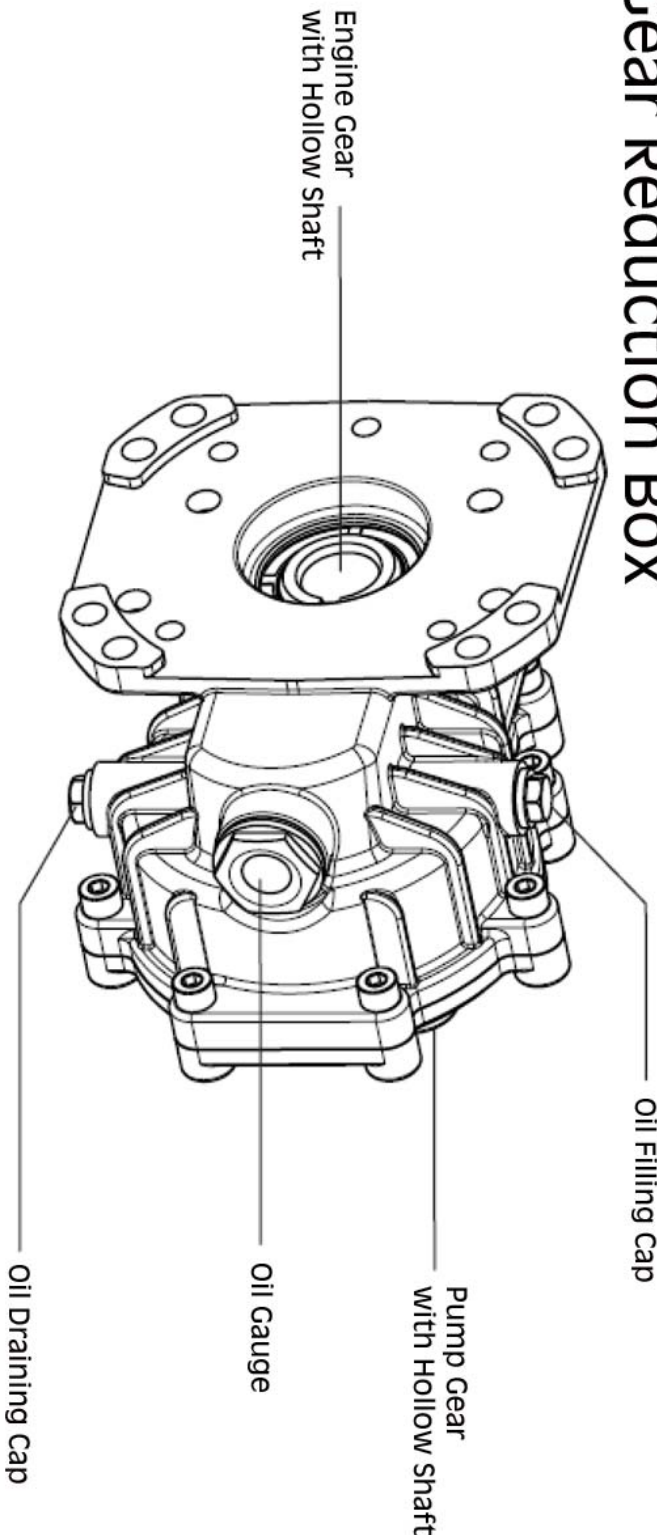

GENERAL TECHNOLOGY

- PSI: Pounds per square inch - Common unit measure used for water pressure, air pressure, hydraulic pressure and pounds of force.
- LPM: Litres per minute - common unit measure used for flow rate of water.
- Bypass Mode: In bypass mode, the high pressure pump recirculates water because the spray gun trigger has not been pressed.

DIESEL ENGINE

1. Air Filter: The air filter prevents airborne contaminants from entering the engine.
2. Fuel Tank: The fuel tank is a reservoir that holds the diesel fuel.
3. Start Motor: It is powered by the battery and engages the flywheel in motion to start the engine.
4. Fuel Switch: To turn 'ON' or 'OFF' the fuel supply to the injection pump.
5. Recoil Starter: Use for starting the engine manually.
6. Decompression Lever: This helps to start the engine by reducing the effort needed to pull the recoil starter handle.

HIGH PRESSURE WATER PUMP

1. Pump Model & Serial Number: It contains the year, month and day of production, and can track the batch of materials, assembler and tester. Please provide the serial no. along with the pump model and version when ordering spare parts and reporting any issues of concern.
2. Pressure Adjusting Knob: Used to raise or reduce the pressure by turning the knob.
3. Detergent Injector: Use to siphon detergent or other pressure washer chemicals into the low pressure stream.
4. Water Outlet Connector: To connect the high pressure hose.
5. Water Inlet with Filter Screen: Used to connect a garden hose to the washer. **ALWAYS** have the filter screen present when in use.
6. Red Shipping Plug Attached with Vent Plug: The pump is shipped with a **RED SHIPPING PLUGS** to prevent oil leaking during transportation. **ALWAYS** replace with the attached vent plugs before using.
7. Thermal Relief Valve: Cycles water through the pump when the water reaches 125-155°F / 50-68°C. Warm water will discharge from the pump onto the ground. This valve can prevent internal pump damage (see page 14).

8. High Pressure Turning Valve: This is a valve that can discharge the air in the pump and water in-take pipeline, enhance pump sucking ability, and allow to suck from a barrel of 1m deep.
9. Easy Start Valve: Releases the head build up pressure which will build when pull starting the engine, and help it easier to start.

ASSEMBLY

FITTING THE WHEELS

1. Insert the axle into the frame as shown.
 - Rotate the axle so that the spring loaded pin pops through the hole on the frame.
2. Fit the wheels to the axles and secure with the washers and locking nuts supplied.

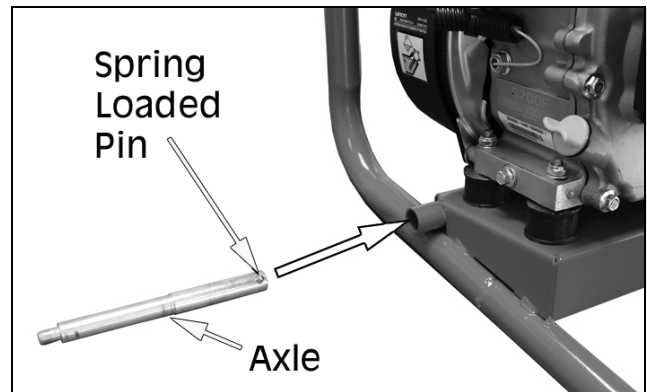

NOTE: **DO NOT** overtighten the locking nuts, the wheels must be able to rotate freely.



CONNECTING THE BATTERY

NOTE: The power washer comes with the battery disconnected. The battery is mounted on the rear of the frame in its own chassis

1. Unscrew the blue negative '-' terminal and attach the blue negative cable, reconnect and tighten the terminal.
2. Unscrew the red positive '+' terminal and attach the red positive cable, reconnect and tighten the terminal.

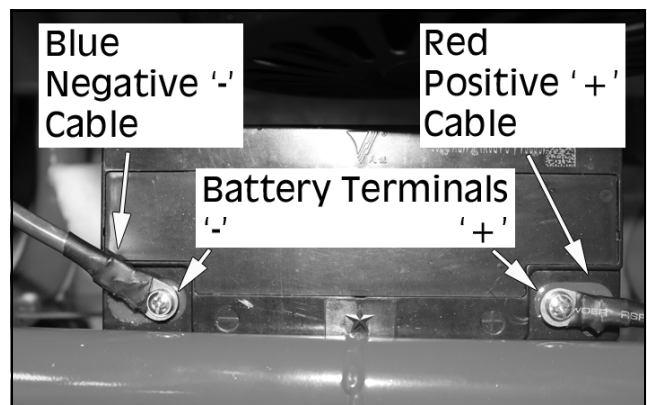

FOLDING HANDLE

1. Lift the handle into the raised open position.
2. Secure in place using the handle locking knobs shown.

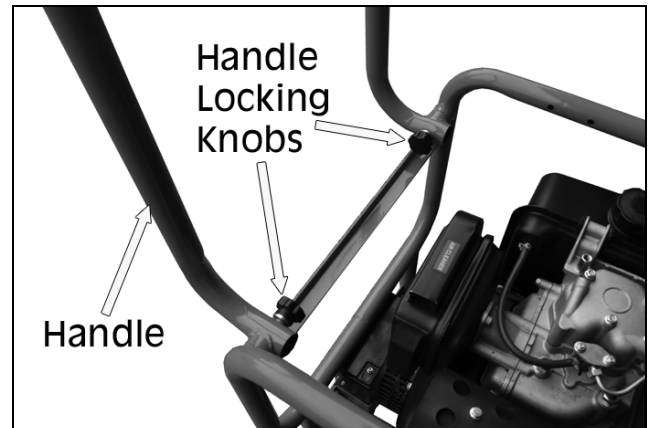

LANCE & HOSE STORAGE BRACKET

1. Fit the bracket into the position shown and secure using the washers and nuts supplied.

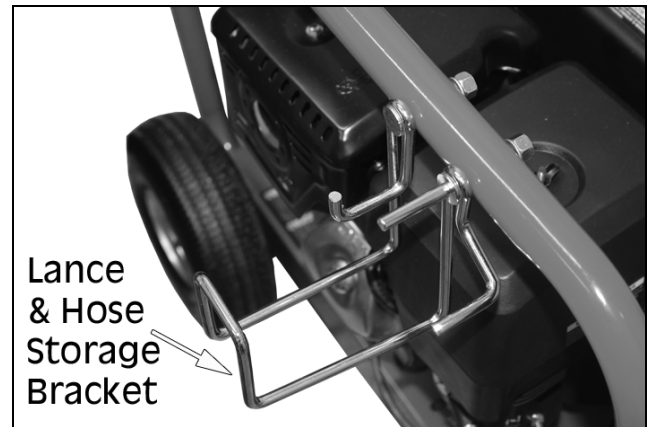

ASSEMBLE THE LANCE

1. Connect the spray wand to the gun and tighten securely by pushing together and turning the M22 swivel fitting.

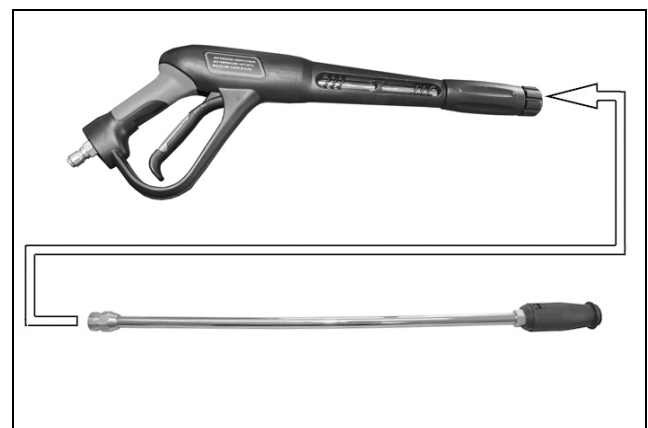

THE HIGH PRESSURE HOSE

CONNECT THE HOSE TO THE GUN

1. Slide the connector collar on the hose backwards.
2. Push the gun into the connector.
3. Release the connector collar.

NOTE: Make sure the connection is secure.

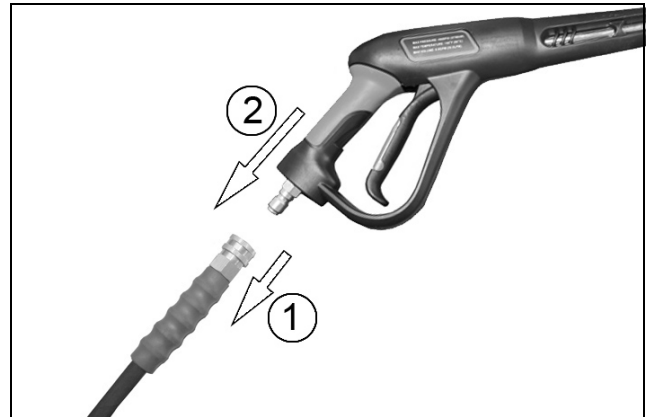

CONNECT THE HOSE TO THE POWER WASHER

1. Slide the connector collar on the power washer towards the machine.
2. Push the hose into the connector.
3. Release the connector collar.

NOTE: Make sure the connection is secure.

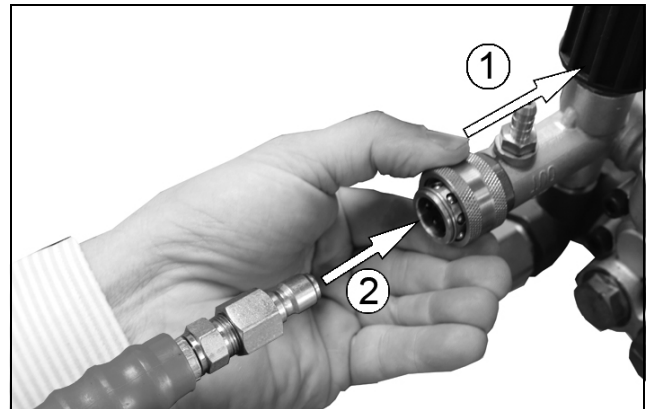

CONNECT WATER INLET HOSE

1. Remove the travel cap if fitted.
2. Fit the hose adaptor as shown.
3. Connect the water supply hose to the hose adaptor.

NOTE: The water source must provide a minimum of 17 litres per minute @ 20 PSI.

NOTE: Make sure the water inlet hose is screwed on tightly.

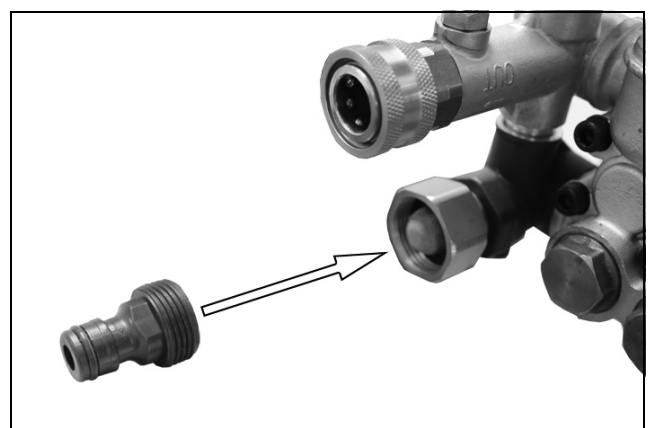

REMOVE THE TRAVEL PLUGS BEFORE USE.

1. Using the 17mm spanner, remove the travel plugs, as shown.

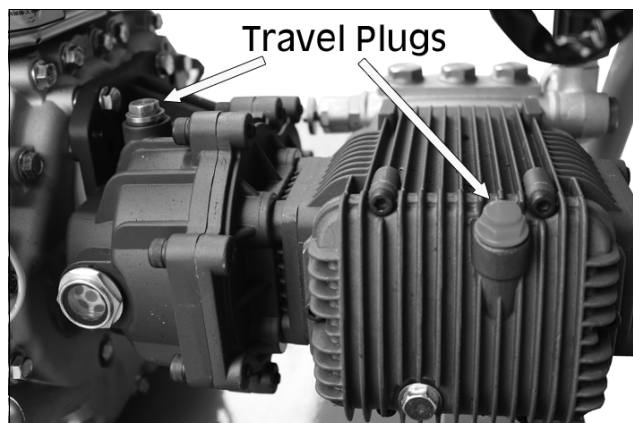

2. Take from the small bag attached the two red topped black breather filler plugs which need to be fitted in their place, as shown.

- The breather filler plugs must only be inserted finger tight.

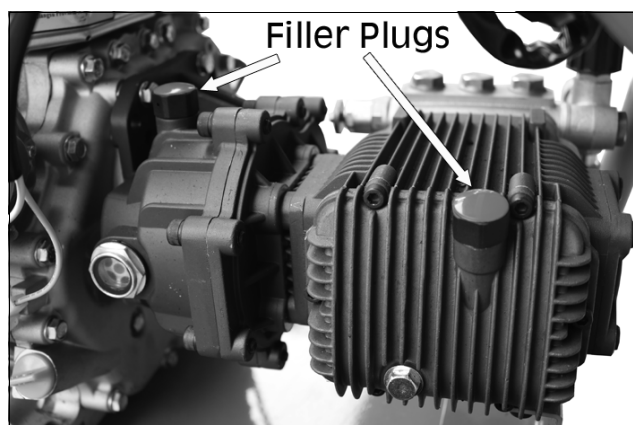

SAFETY FEATURES

Bypass mode: In bypass mode, the pump recirculates the water because the trigger of the spray gun is not being pulled. If the unit is left unused for more than two minutes, the water temperature will rise to a dangerous level and could damage internal components of the pump. If this is the case, the Thermal Relief Valve will automatically engage. If the gun will not be used for a longer period or the thermal relief valve does not operate, switch off the engine.

Thermal Relief Valve: In an effort to prevent damage, pumps are equipped with a thermal relief valve. This valve will open when the temperature inside the pump becomes too high. The valve will then release a gush of water in an effort to lower the temperature inside the pump. Immediately after this occurs, the valve will close.



Trigger Safety Switch: The trigger on the gun has a safety switch to protect against accidental activation of the washer. To deactivate the switch, push the switch down into the trigger. **ALWAYS** move the switch back into the safe up position when not in use or while being stored.



BEFORE USE



WARNING: TO CARRY OUT THIS CHECK, PLACE THE POWER WASHER ON LEVEL GROUND WITH THE ENGINE SWITCHED OFF.

IMPORTANT: *The engine is supplied without any oil in it and must be filled to the correct level before use, see below.*

NOTE: All oil levels should be checked when the engine is cold, as you may get a false reading with a hot engine.

ENGINE OIL RECOMMENDATIONS

SAE 10W-30 oil is recommended for general use, other viscosities shown in the chart may be used when the average temperature in your area is within the indicated range.

NOTE: Below 40°F (4°C), the use of SAE 30 oil will result in hard starting.

NOTE: Above 80°F (27°C), the use of 10W30 may cause increased oil consumption.

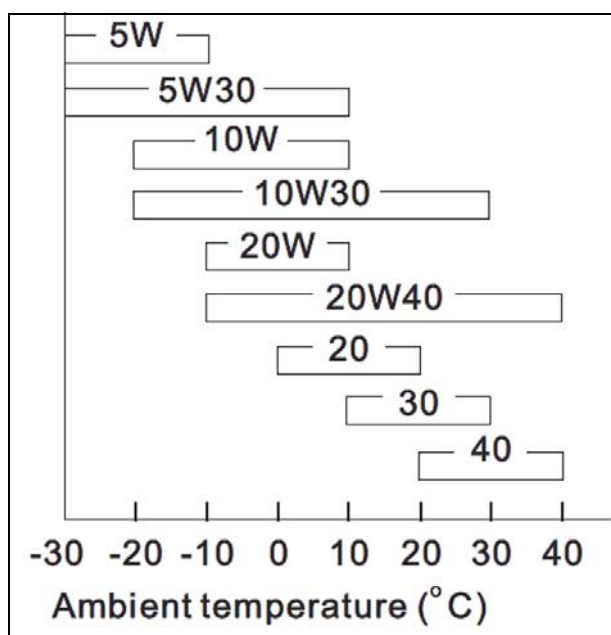

CHECKING THE ENGINE OIL LEVEL



WARNING: RUNNING THE ENGINE WITH INSUFFICIENT OIL WILL CAUSE ENGINE DAMAGE.

1. Turn the oil filler cap/dipstick anti-clockwise and remove it from the oil filler tube.
2. Wipe the oil filler cap/dipstick with a clean cloth.
3. Insert the oil filler cap/dipstick back into the oil filler tube and then remove it again. **DO NOT** screw it in when doing this.
4. If the oil is low, fill the oil reservoir to the edge of the oil filler hole, as shown.
 - We recommend the use of SAE10W/30 oil in the engine.
5. Replace the oil filler cap.

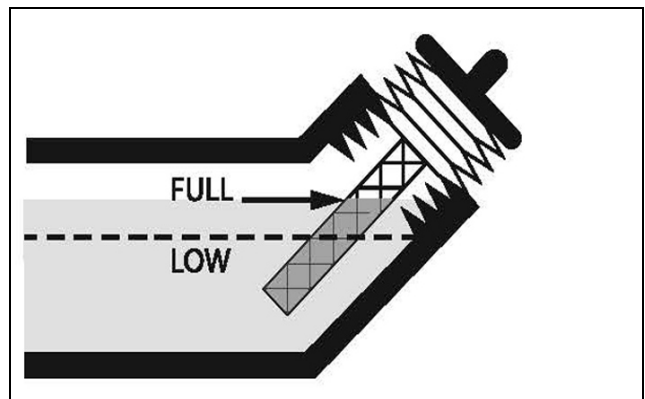
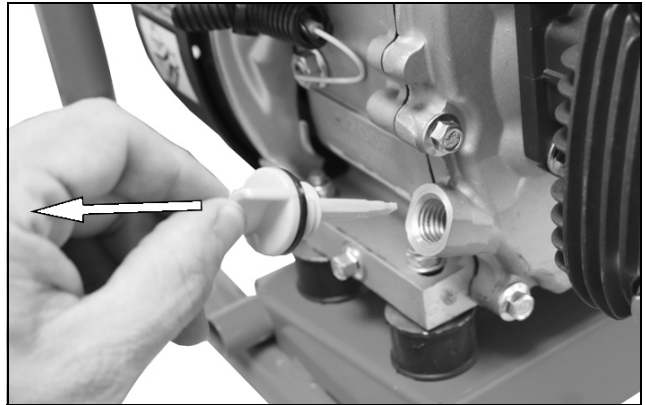

CHECKING THE PUMP & GEARBOX OIL LEVEL

1. Look at the sight glass on the pump and gearbox to check the oil levels inside.
 - The oil should be half way up the sight glass.

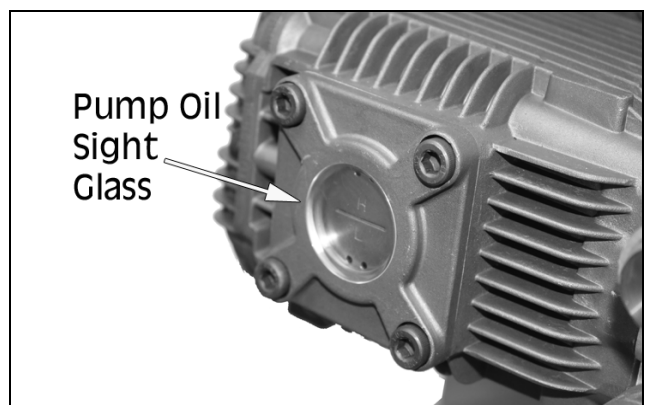

2. If required, top up with oil.

- We recommend the use of SAE10W/30 oil.

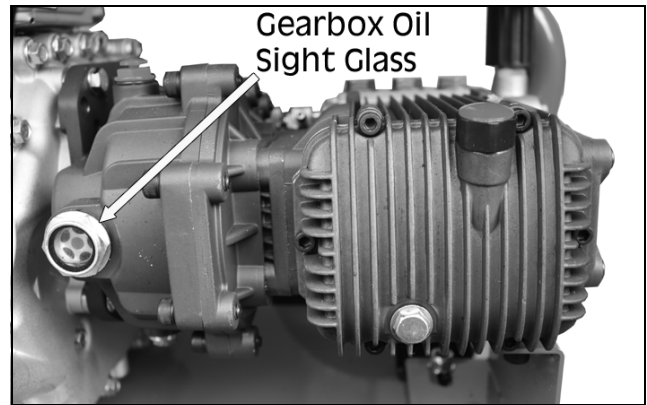

CHECKING THE FUEL LEVEL



WARNING: ALWAYS REFUEL IN A WELL VENTILATED AREA AWAY FROM ANY SOURCES OF IGNITION AND HEAT.

WARNING: ALLOW THE UNIT TO COOL DOWN BEFORE REFUELLING.

WARNING: DO NOT LEAVE FUEL WITHIN THE REACH OF CHILDREN.

NOTE: Always check the fuel level before use. Never run the engine when fuel level is near empty, as this may damage the engine.

1. To check the fuel level, remove the fuel tank cap.
2. Just inside the fuel tank is a fuel strainer. Check this filter periodically and remove any contaminants which may have accumulated.
3. Refuel in a well-ventilated area before starting the engine. If the engine has been running, allow it to cool. Refuel carefully to avoid spilling fuel. **DO NOT** fill above the fuel strainer shoulder.
4. After refueling, replace the fuel filler cap securely.

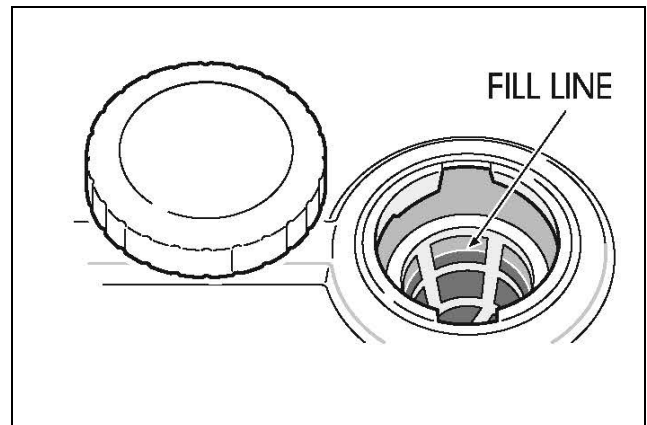

RECOMMENDED FUEL

Use Ultra Low Sulfur Diesel (ULSD). **DO NOT** overfill.

PRESSURE REGULATOR

When purchased, the pressure regulator may be set to minimum.

Turn the pressure regulator on the pump fully clockwise to allow water pressure to increase when the pressure washer is running.

If you find the pressure is too high, you can adjust this later by turning the regulator anti-clockwise.

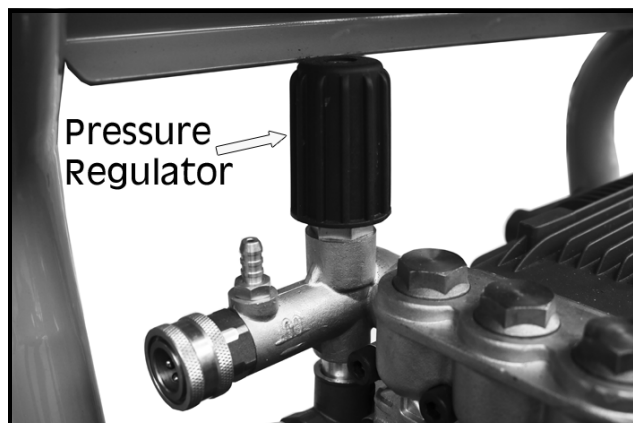

STARTING YOUR POWER WASHER



WARNING: FAILURE TO TURN ON THE WATER COULD CAUSE DAMAGE TO THE PUMP.

ELECTRIC START

Prior to starting, refer to your engine manual for the starting procedures for your engine type.

1. Make sure the engine has sufficient fuel. See page 17.
2. Check the engine, pump & gearbox oil levels. See page 15-16.
3. Connect the high pressure hose and water inlet hoses. See page 13.
4. Turn water supply on.
5. Set the fuel valve lever to the 'ON' position.



6. Loosen the engine speed control knob anti-clockwise and slide the engine speed control knob down to the 'START' position and tighten in position.

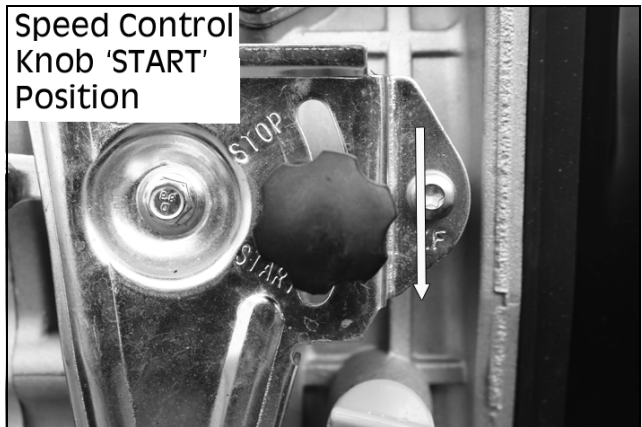

7. Turn the key clockwise to the 'START' position. Release the key as soon as the engine starts. It will return to the 'ON' position.



NOTE: If the engine fails to start:

1. Wait until the engine completely stops. Engaging the starter while the engine is rotating may cause damage to the starter motor and flywheel.
2. Wait at least 30 seconds before you attempt to restart the engine again.

IMPORTANT: Allow the engine to run at no load for five minutes after each start up so the engine can stabilise.

RECOIL START

1. Make sure the engine has sufficient fuel. See page 17.
2. Check the engine, pump & gearbox oil levels. See page 15-16.
3. Connect the high pressure hose and water inlet hoses. See page 13.
4. Turn water supply on.

5. Set the fuel valve lever to the 'ON' position.

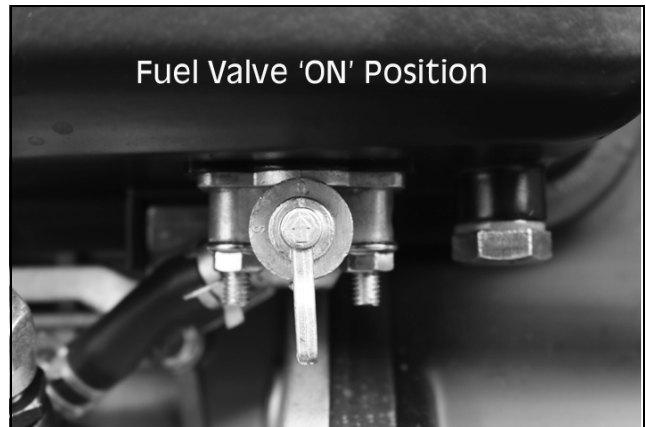

6. Loosen the engine speed control knob anti-clockwise and slide the engine speed control knob down to the 'START' position and tighten in position.

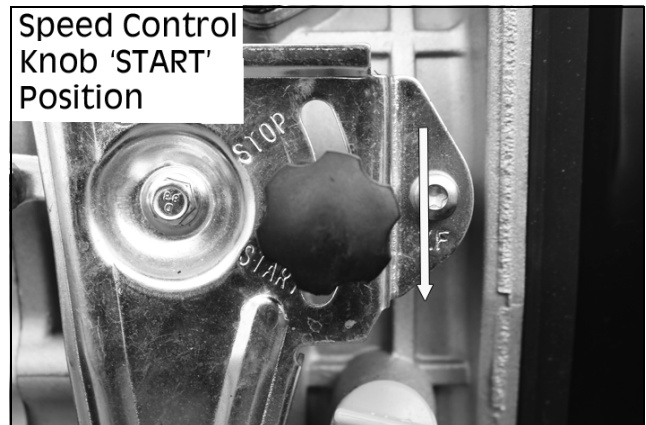

7. Hold the Recoil Starter handle firmly. Slowly pull the handle until you feel resistance, then let it return to its start position.

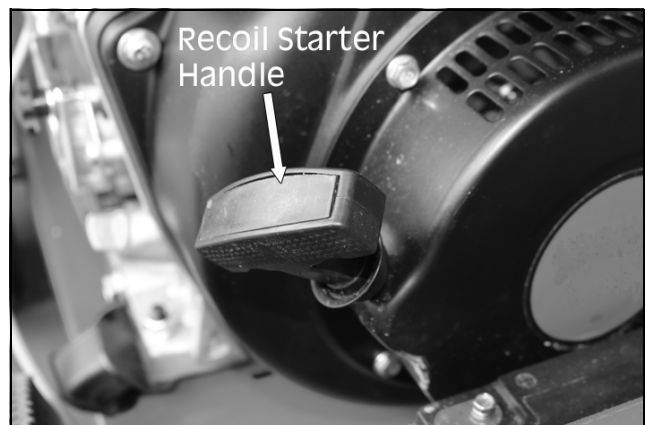

8. Push the green Decompression Lever (located on top of the engine) into the down position.

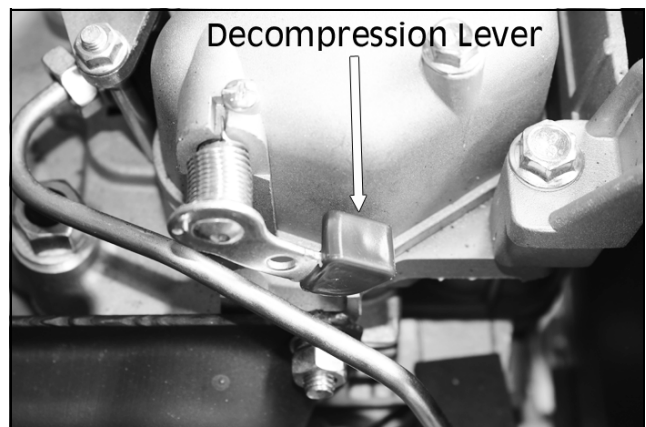

9. Take hold of the Recoil Starter handle again and pull it hard and fast all the way out, using two hands if necessary.

COLD START IN WINTER

If the engine is difficult to start in winter, see the engine manual for instructions on how to cold start.

Different oil grades may be required to help start in colder weather. See page 15 for more information.

USING THE POWER WASHER

1. Pull the trigger on the gun to start water flow.
 - Stand on a stable surface and grip the gun/spray wand firmly with both hands.
 - Expect the gun to kick when the trigger is pulled.
2. Release the trigger to stop water flow.

NOTE: The power washer will automatically go into bypass mode when the trigger is not being pressed. See Safety Features section on page 14-15 for more information.



WARNING: DO NOT ALLOW THE UNIT TO OPERATE IN BYPASS MODE FOR MORE THAN TWO MINUTES AT ANY TIME.

ADJUSTING THE SPRAY

The nozzle is adjustable to allow you to change the spray from a narrow jet of water to a wide spray.

To adjust the nozzle, proceed as follows.

1. Hold the shaft of the spray wand in one hand.
2. Twist the nozzle with the other hand.
3. To vary the spray between narrow and wide, turn the nozzle counter-clockwise through a half-of-a-turn.

- Slide the nozzle forward for low pressure and backwards for high pressure.

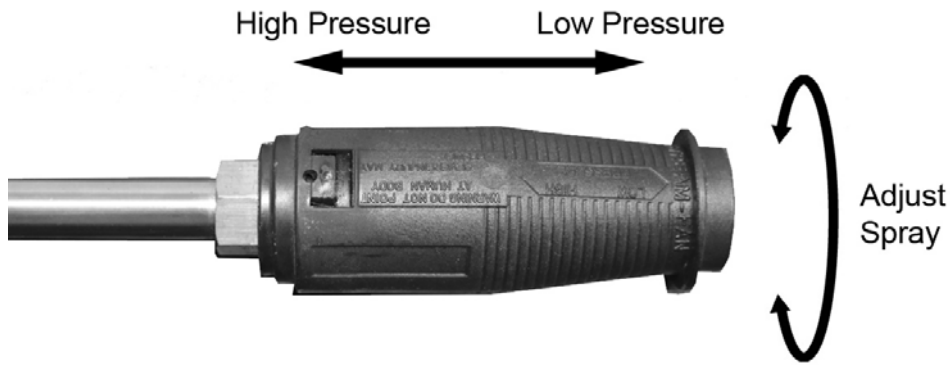

ADJUSTING THE PRESSURE

There are 4 ways to adjust the pressure.

1. Adjust the pressure regulator on the pump. Turn the pressure regulator knob counter clockwise to lower pressure. Once you have finished using your power washer, return the pressure regulator to its original position.
2. Back away from the surface to be cleaned. The further away you are, the less the pressure will be on the surface being cleaned.
3. Reduce the speed of the engine (RPM). Slow the engine down and the water pressure will also go down.
4. Adjust the spray to a wider angle.
 - Slide the nozzle forward for low pressure and backwards for high pressure.

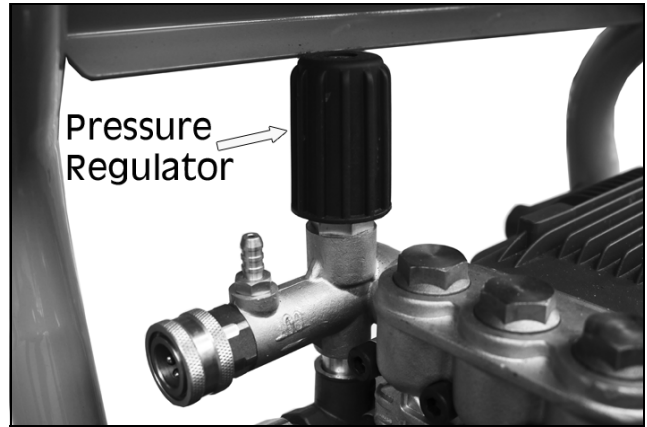

APPLYING DETERGENTS AND CLEANING SOLVENTS

NOTE: Use only detergents designed for pressure washers; household detergents, acids, alkalines, bleach, solvents, flammable material or industrial grade solutions can damage the pump. Many detergents may require mixing prior to use. Prepare the cleaning solution as instructed on the solution bottle.

SET UP PROCEDURE

1. Push the detergent hose onto the ribbed fitting as shown.
2. Place the other end of the detergent hose with the filter on it, into a container holding the chemical/cleaning solution.
3. Slide the nozzle forward for low pressure operation.

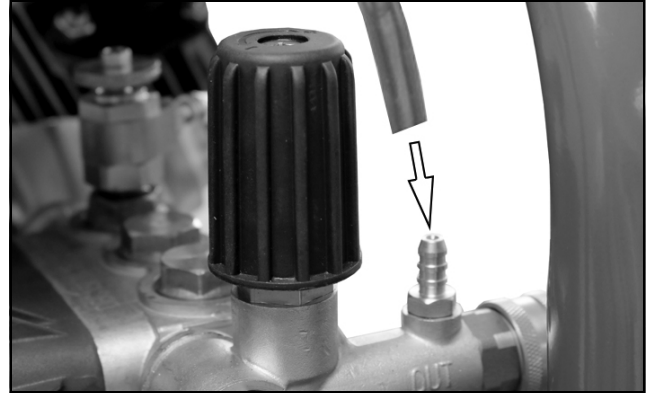

NOTE: See page 28 for detergent and cleaning products available from your CLARKE dealer.

CHEMICAL CLEANING

1. Spray the chemicals onto a dry surface using the procedures outlined above. Start at the lower portion of the cleaning area and working upwards, using long, even, overlapping strokes.
2. Always ensure that the filter is fully submerged in the cleaning solution at all times.
3. Allow the detergent to soak in for 3-5 minutes before washing and rinsing.
4. Re-apply as needed to prevent the surface from drying. **DO NOT** allow the detergent to dry on to the cleaning surface to prevent streaking.

AFTER CHEMICAL CLEANING

IMPORTANT: You will need to flush the detergent siphoning system after each use by placing the filter into a bucket of clean water, then run the pressure washer in low pressure for 1-2 minutes.

1. After using chemicals, soaps or detergents, it is necessary to thoroughly clean the pressure washer.
2. Place the chemical hose in a container of clean water.
3. Start the pressure washer and hold the trigger on the spray gun to draw clean water through the system to clean it thoroughly.

WATER BUTT CONNECTION

This machine has the ability to draw its own water, meaning you can use water not under pressure, such as rainwater collected in a water butt. To do this you must carry out the following procedure.

1. Attach the filter to the end of the pipe supplied.
2. Place the filter into the water butt.

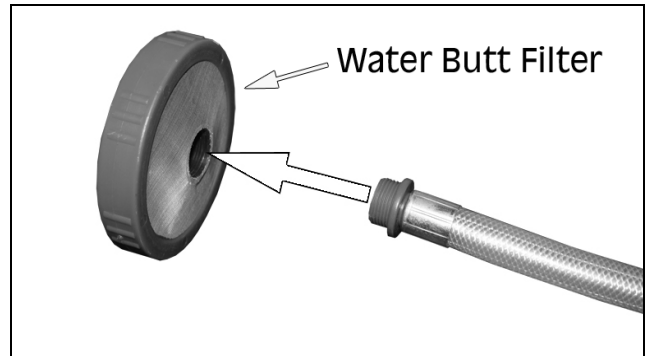

3. Remove the hose adaptor and replace it with the inlet connector supplied.

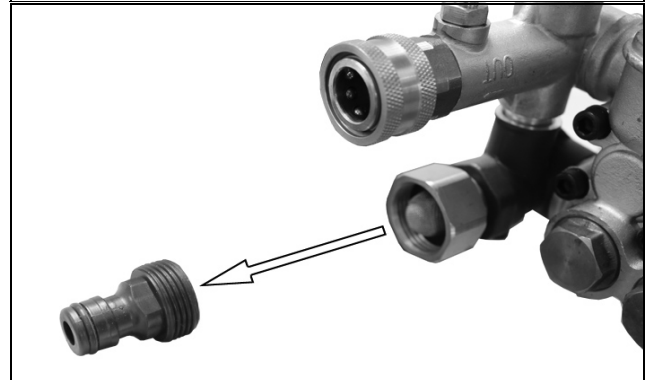

4. Connect the pick-up pipe to the pressure washer as shown.
 - Tighten securely

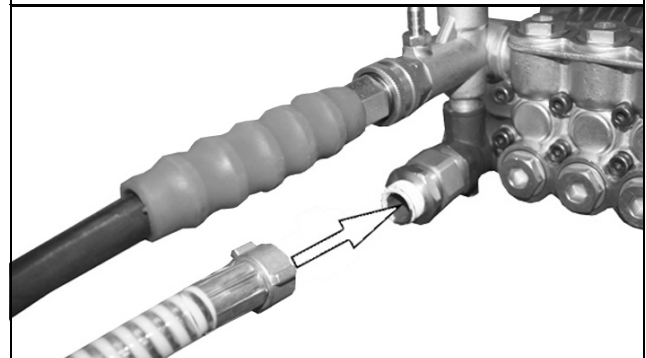

5. Twist open the suction valve shown.
6. Start the power washer. See Starting your Power Washer on page 18 onwards.
 - Water is ejected from the nozzle.



7. When the water spray being ejected is consistent and at high pressure, close the suction valve.
8. Use the pressure washer as normal.

NOTE: DO NOT LET THE PRESSURE WASHER RUN DRY.

SHUTTING DOWN

1. Release the spray gun trigger and allow the engine to run unloaded for 3 minutes before shutting down.
2. Loosen the engine speed control knob anti-clockwise and slide the knob up to the 'STOP' position. Tighten the knob clockwise in the 'STOP' position.



3. Turn the engine switch key to the 'OFF' position and remove the key.



4. Rotate the fuel valve to the 'OFF' position.
5. Turn the water supply off.
6. Pull the trigger on the spray gun to release any water pressure.
7. Engage the gun trigger safety switch.
8. See storage section on page 29 for proper storage procedures.

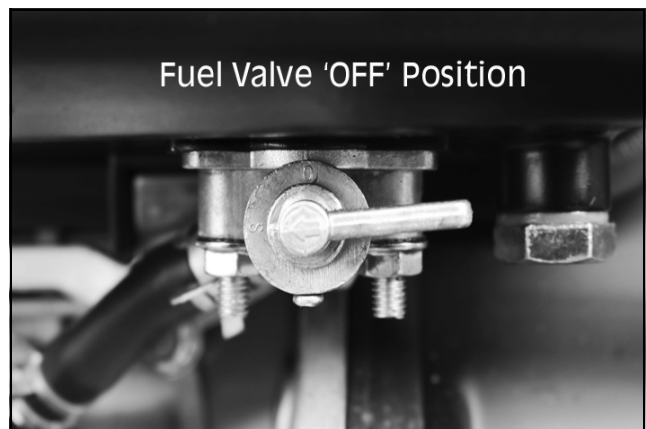

NOTE: NEVER TURN THE WATER OFF WITH THE ENGINE RUNNING.

MAINTENANCE

CHANGING THE PUMP OIL



CAUTION: PROLONGED EXPOSURE TO USED OIL IS DANGEROUS, ALWAYS WASH YOUR HANDS THOROUGHLY AFTER HANDLING USED OIL.

Change the pump oil regularly. You should change the oil after the first 50 hours of use and successively every 200 hours or 3 months, whichever occurs first. In either case ensure that the oil is changed at least once a year.

1. Unscrew and remove the oil filler cap.
2. Place an oil collection tray (not supplied) under the drain plug.
3. Unscrew the drain plug, and allow the used oil to drain from the crankcase into the oil collection tray.

NOTE: It is best to drain the oil when the engine is warm, this will ensure the oil flows out quicker.

4. Replace the drain plug and its ring seal.
5. With the power washer on a level surface, fill to the centre of the sight-glass with the recommended oil.
6. Replace the oil filler cap.

RECOMMENDED OIL

- See page 15 for more information on types of oil.

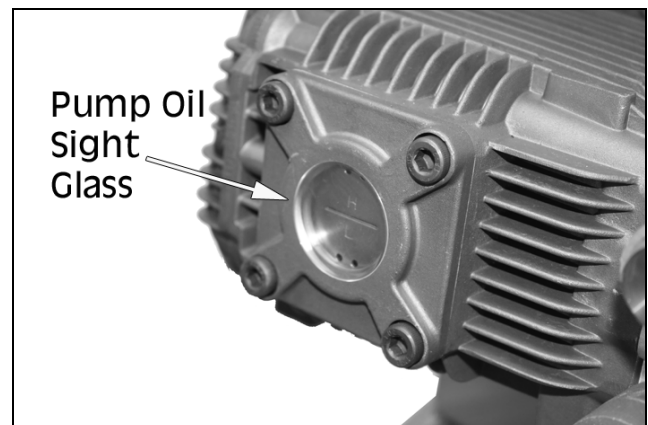
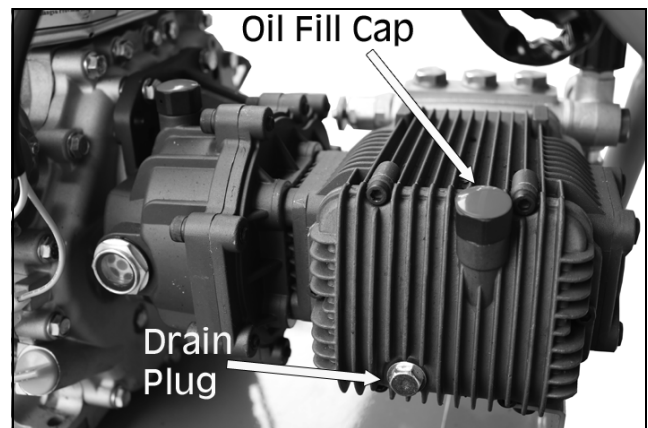

ENVIRONMENTAL PROTECTION

One of the most damaging sources of pollution is oil. **DO NOT** throw away used oil with your domestic rubbish or down drains and sinks. Place it in a leak proof container and take it to you local waste disposal site.

CLEANING THE WATER INLET

The water filter should be checked regularly and cleaned if necessary.

1. Remove any fittings to the water inlet.
2. Remove the water filter from the water inlet.
3. Clean the filter by flushing it with water on both sides
4. Replace the water filter.

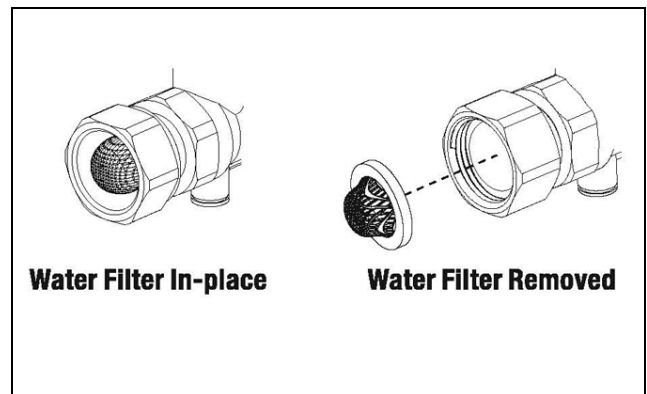

CHECKING THE AIR FILTER



CAUTION: DO NOT USE THE PRESSURE WASHER WITHOUT THE AIR FILTER FITTED, THIS CAN DAMAGE THE ENGINE.



WARNING: DO NOT USE FLAMMABLE SOLVENTS OR PETROL TO CLEAN THE AIR FILTER.

1. Remove the wingnut and the air filter cover.

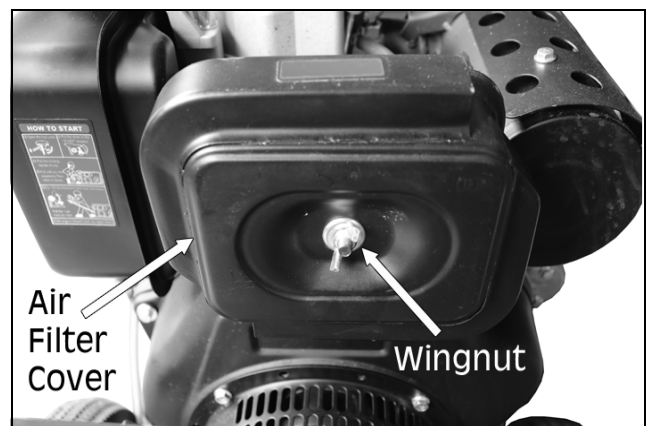

2. Remove the second nut shown and remove the filter.

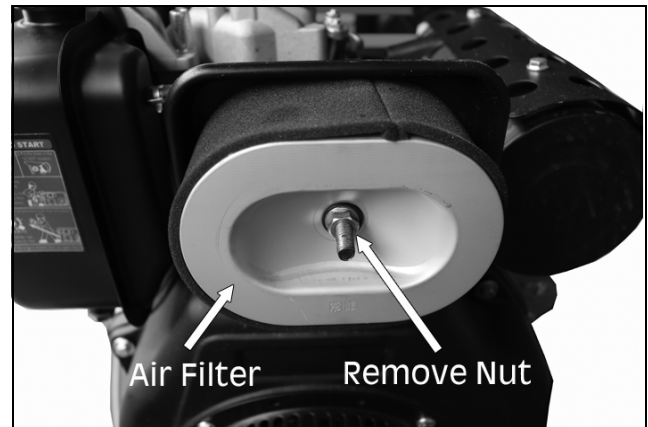

3. Make sure that the air filter is clean and not damaged.
 - If the air filter is damaged contact CLARKE parts department for a replacement.
 - If the filter is dirty, wash it in a solution of warm water and mild detergent and rinse thoroughly. Leave the filter to dry completely; before immersing the filter in clean engine oil and squeeze the filter to remove excess oil.
4. Replace the filter and the air filter cover.

STORAGE

ENGINE

See the separate engine manual supplied for information regarding the storage procedure.

PUMP

1. Drain all water from the high pressure hose, coil it and store it on the hose holder, located on the side of the power washer.
2. Drain all water from the spray gun and spray wand by holding the gun/wand vertically with the nozzle pointing down, and pulling the trigger. Store in the gun holder on the side of the power washer.
3. Store all other parts so that they are protected from damage.
4. Protect the power washer from freezing conditions to prevent damage to the hoses, valves and pump.

STORAGE PROCEDURE

For long term storage, the fuel tank should be drained. Ensure that the engine is cold before draining the tank. Remove the fuel tank cap and use a pump type syphon to drain the fuel into an appropriate, clean container.

5. Dispose of excess fuel in an environmentally safe way. Your local recycling centre can advise you on the best method of disposal. After the fuel tank has been drained, start the engine and allow it to use any fuel that may remain in the engine or fuel pipe. Make sure that the power washer has been thoroughly cleaned before storing it in a clean dry place.

ASSOCIATED CLARKE PRODUCTS

Wash & Wax Car Shampoo - PWWS2L	Traffic Film Remover - 5 Litre
	
<ul style="list-style-type: none"> • 2 Litre • Can be used with a power washer or by hand • Part No. 3050817 	<ul style="list-style-type: none"> • 5 Litre • Makes up to 3000L of cleaner • Part No. 3050821

TROUBLESHOOTING

If the following does not solve your problem, please contact the CLARKE service department.

PROBLEM	PROBABLE CAUSE	SOLUTION
Engine shuts down when running	1) Out of fuel 2) Low engine oil	1) Fill fuel tank 2) Add oil
Engine will not start; or starts and runs rough (see engine manual for further engine troubleshooting)	1) Rocker switch set to 'OFF' position 2) Fuel valve is in 'OFF' position 3) Dirty air filter 4) Out of fuel 5) Stale fuel 6) Water in fuel 7) Flooded 8) Excessively rich fuel/air mixture 9) Intake valve stuck open or closed 10) Engine has lost compression 11) Low engine oil 12) Wrong fuel 13) Engine is too hot 14) Pressure build up after 2 pulls on recoil starter or after initial use	1) Set switch to 'ON' position 2) Turn fuel valve to 'ON' position 3) Clean or replace air filter 4) Fill fuel tank 5) Drain fuel tank and carburetor; fill with fresh fuel 6) Drain fuel tank and carburetor; fill with fresh fuel 7) Wait 5 minutes and re-crank engine 8) Contact CLARKE service department 9) Contact CLARKE service department 10) Contact CLARKE service department 11) Add oil 12) Use recommended fuel (Diesel) 13) Allow engine to cool 14) Squeeze gun trigger to relieve pressure
Engine lacks power	1) Cylinder pressure is low 2) Dirty air filter	1) Contact CLARKE service department 2) Replace air filter

PROBLEM	PROBABLE CAUSE	SOLUTION
Starter motor operates but engine does not start	1) No fuel 2) Improper fuel 3) Clogged fuel filter 4) Poor fuel injection 5) Compressed air leakage from the intake/exhaust valves	1) Refuel system 2) Replace with diesel fuel 3) Replace fuel filter 4) Contact CLARKE service department 5) Contact CLARKE service department
Starter motor does not operate or rotates too slowly	1) Battery low or out of charge 2) Faulty cable connection at battery terminals 3) Faulty starter switch 4) Faulty starter motor	1) Battery needs charging 2) Clean battery terminals, retighten 3) Contact CLARKE service department 4) Contact CLARKE service department
Black exhaust smoke	1) Engine overloaded 2) Clogged air filter element 3) Improper fuel 4) Faulty spraying of fuel injection 5) Excessive intake/exhaust valve clearance	1) Reduce load 2) Clean element and/or replace 3) Replace with diesel fuel 4) Contact CLARKE service department 5) Contact CLARKE service department
White exhaust smoke	1) Improper fuel 2) Faulty spray pattern of fuel injection 3) Fuel injection timing delay 4) Engine burning oil	1) Replace with diesel fuel 2) Contact CLARKE service department 3) Contact CLARKE service department 4) Contact CLARKE service department

PROBLEM	PROBABLE CAUSE	SOLUTION
No pressure or low pressure	1) Spray wand not set to high pressure 2) Low water supply 3) Hose fitting leaks during high pressure 4) Water filter screen obstructed 5) Defective thermal relief valve 6) Air in hose 7) Throttle control lever is not in fast position 8) High pressure hose too long	1) See 'Adjusting the Spray' section (page 21-22) 2) Water supply must be 19 LPM @ 20PSI 3) Tighten hose fittings. Use thread sealant tape if necessary 4) Remove and clean filter (see page 27) 5) Contact CLARKE service department 6) Stop engine and water source. Disconnect water source from pump inlet and turn water source to ON to remove all air from the hose. When steady stream of water is present, turn water source to OFF. Reconnect water source to pump inlet and turn on water source. Squeeze trigger to remove remaining air 7) Move throttle control lever from fast position 8) Use high pressure hose under 100ft (30m)
No or low pressure - after period of normal use	1) Worn seal or piston packing 2) Worn or obstructed valves 3) Worn unloader piston 4) Worn E-Z start valve	1-4) Have parts cleaned or replaced by an authorised CLARKE dealer

PROBLEM	PROBABLE CAUSE	SOLUTION
Pump will not draw chemicals	1) Spray wand not set to low pressure 2) Chemical filter clogged 3) Chemical screen not in chemical 4) Chemical solution too thick 5) Pressure hose too long 6) Chemical build up in chemical injector	1) See 'Adjusting the Spray' section (page 21-22) 2) Clean filter 3) Ensure end of chemical hose is fully submerged into chemicals 4) Dilute chemical. Chemical solutions should have same consistency as water 5) Lengthen water supply hose instead of pressure hose 6) Have parts cleaned or replaced by an authorised CLARKE dealer
Water leaking at pump	1) Loose connections 2) Piston packings worn 3) Worn or broken O rings 4) Pump head or tubes damaged from freezing	1) Tighten hose connections 2) Have parts cleaned or replaced by an authorised CLARKE dealer 3) Check and replace O ring 4) Have parts cleaned or replaced by an authorised CLARKE dealer
Water leaking at spray gun/spray wand connection	1) Worm or broken O ring 2) Loose hose connection	1) Check and replace O ring 2) Tighten hose connections
Oil leaking at pump	1) Oil Seals worn 2) Loose drain plug 3) Worn drain plug O ring 4) Worn fill plug O ring 5) Pump overfilled 6) Incorrect oil used 7) Vent plug clogged	1) Have parts cleaned or replaced by an authorised CLARKE dealer 2) Tighten drain plug 3) Inspect and replace O ring 4) Inspect and replace O ring 5) Check for correct oil amount 6) Drain and refill with correct type and amount of oil 7) Clean vent plug. Use a blast of air to free it of blockage. If problem persists, replace vent plug

DECLARATION OF CONFORMITY



DECLARATION OF CONFORMITY

This is an important document and should be retained.

We hereby declare that this product(s) complies with the following legislation: The following standards have been applied to the product(s):

Noise Emission in the Environment by Equipment for use Outdoors Regulations 2001

The Electromagnetic Compatibility Regulations 2016

The Supply of Machinery (Safety) Regulations 2008

The Restriction of the Use of Certain Hazardous Substances in Electrical and Electronic Equipment Regulations 2012

The Batteries and Accumulators (Placing on the Market) Regulations 2008

IEC 62321-4:2013+AMD1:2017, EN 1679-1:1998+A1:2011, EN 55012:2007+A1:2009,

EN 60335-2-79:2012, IEC 62321-7-1:2015, IEC 62321-7-2:2017, EN ISO 12100:2010,

EN ISO 3744:2010, IEC 62321-5:2013, IEC 62321-6:2015, IEC 62321-8:2017

The technical documentation required to demonstrate that the product(s) meet(s) the requirement(s) of the aforementioned legislation has been compiled and is available for inspection by the relevant enforcement authorities.

The UKCA mark was first applied in: 2023

Manufacturer: Clarke International Ltd, Hemnall Street, Epping, Essex, CM16 4LG, United Kingdom

Notified Body: N/A

Product Description: Pressure Washer

Assessment Procedure: Annex V of above noise legislation

Model Number(s): DLS360

Measured LWA: 110.71 dB

Serial/Batch Number: Refer to product/packaging label

Guaranteed LWA: 111 dB

Document Holder: Alan Pond

Signed:

J.A Clarke

Date of Issue: 20/12/2023

Director

DLS360 UKCA Clarke DOC 122023

Page 1 of 1



DECLARATION OF CONFORMITY

This is an important document and should be retained.

We hereby declare that this product(s) complies with the following legislation: The following standards have been applied to the product(s):

2000/14/EC Outdoor Noise Directive

2014/30/EU Electromagnetic Compatibility Directive

2006/42/EC Machinery Directive

2011/65/EU Restriction of Hazardous Substances (RoHS) Directive

2023/1542 Battery Regulation

IEC 62321-4:2013+AMD1:2017, EN 1679-1:1998+A1:2011, EN 55012:2007+A1:2009,

EN 60335-2-79:2012, IEC 62321-7-1:2015, IEC 62321-7-2:2017, EN ISO 12100:2010,

EN ISO 3744:2010, IEC 62321-5:2013, IEC 62321-6:2015, IEC 62321-8:2017

The technical documentation required to demonstrate that the product(s) meet(s) the requirement(s) of the aforementioned legislation has been compiled and is available for inspection by the relevant enforcement authorities.

The CE mark was first applied in: 2023

Manufacturer: Clarke International Ltd, Fitzwilliam Hall, Fitzwilliam Place, Dublin 2, Republic of Ireland

Notified Body: N/A

Product Description: Pressure Washer

Assessment Procedure: Annex V of above noise legislation

Model Number(s): DLS360

Measured LWA: 110.71 dB

Serial/Batch Number: Refer to product/packaging label

Guaranteed LWA: 111 dB

Document Holder: Alan Pond

Signed:

J.A Clarke

Date of Issue: 20/12/2023

Director

DLS360 CE Clarke DOC 122023

Page 1 of 1

EXPLODED DIAGRAM & PARTS LIST- GEAR BOX

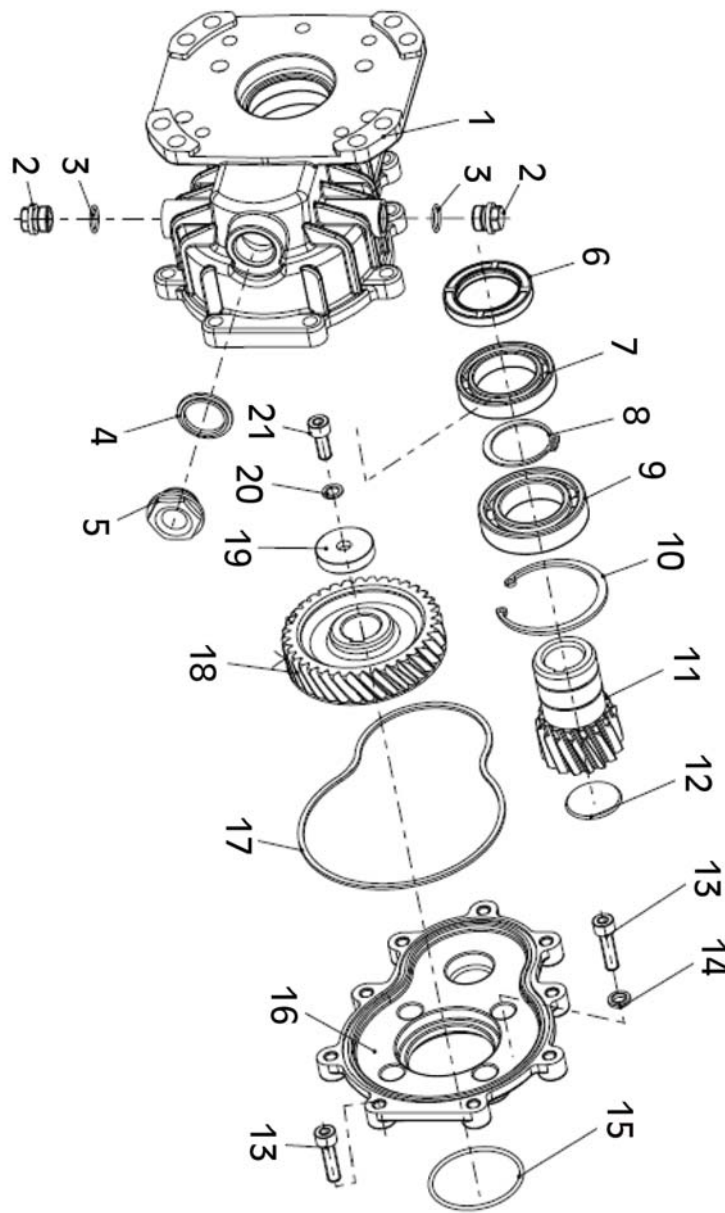

1	Gearbox Case
2	Oil Plug
3	O Ring 14.2*1.9
4	Gasket, Oil gauge
5	Sight Gauge
6	Oil Seal
7	Ball Bearing Casing 61908
8	Snap Ring D40
9	Ball Bearing Casing 6008
10	Snap Ring D68
11	Engine Gear

12	Blocking Flake
13	Bolt M8*30
14	Combine Washer
15	O Ring 55.25*2.62
16	Gearbox Cover
17	Gasket Cover
18	Pump Gear
19	Ring
20	Washer 08
21	Bolt M8*20

EXPLODED DIAGRAM & PART LIST - PUMP

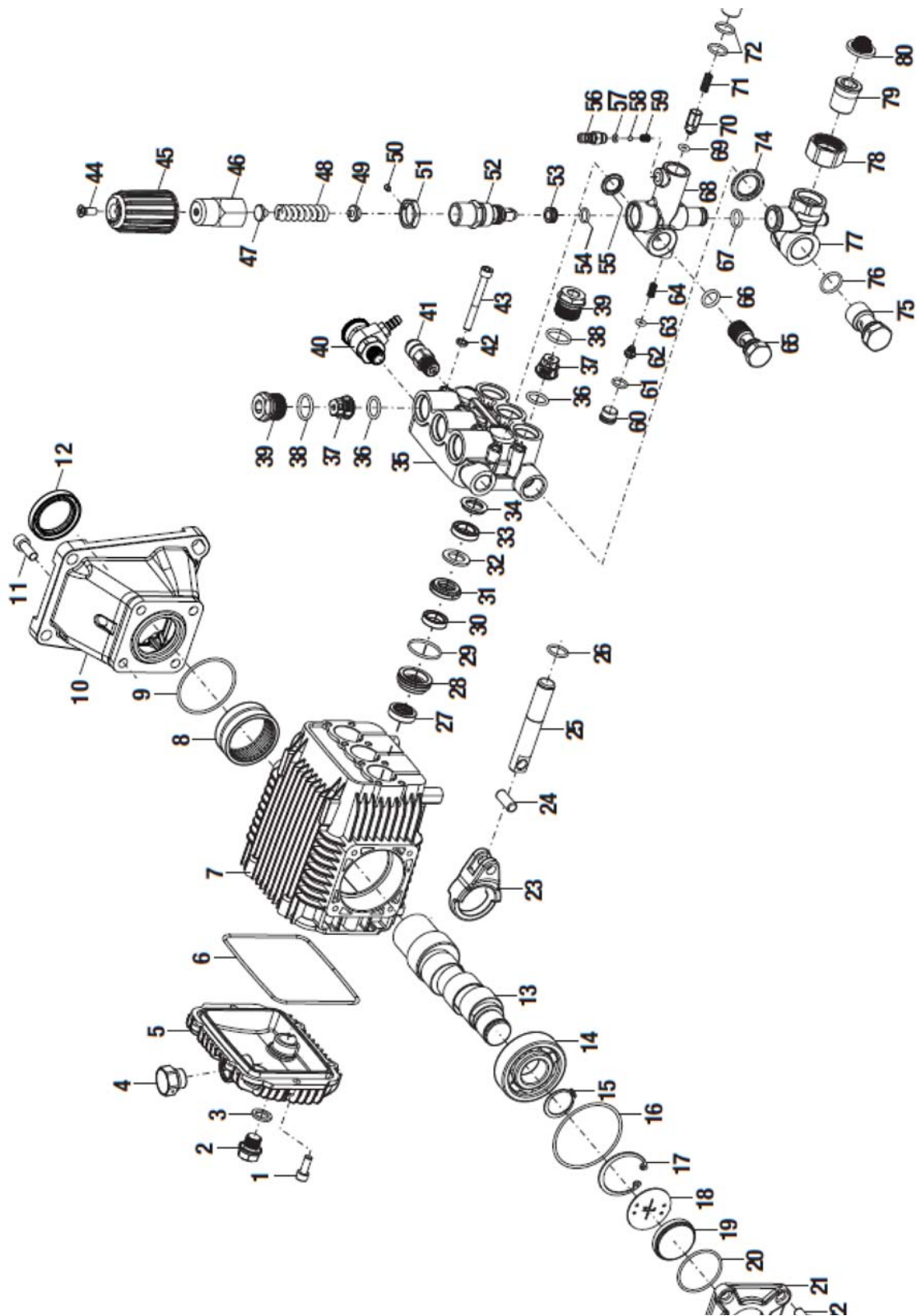

1	Bolt, Crankcase Cover
2	Oil Drain Plug
3	O Ring, Oil Drain Plug
4	Vented Oil Cap
5	Crankcase Cover
6	Gasket, Crankcase Cover
7	Crankcase
8	Needle Bearing
9	O Ring, Flange
10	Flange
11	Bolt, Flange
12	Oil Seal, Flange
13	Crankshaft
14	Ball Bearing
15	Scrap Ring
16	O Ring, Crankshaft Cover
17	Retain Ring
18	Oil Level Plate
19	Oil Sight Glass
20	O Ring, Oil Sight Glass
21	Crankshaft Cover
22	Bolt, Crankshaft Cover
23	Connecting Rod
24	Pin
25	Ceramic Coating Plunger
26	O Ring
27	Oil Seal, Plunger
28	Locating Ring
29	O Ring, Locating Ring
30	Low Pressure Water Seal
31	Compression Ring
32	Compression Flake
33	High Pressure Water Seal
34	Supporting Ring
35	Manifold
36	O Ring, Checking Valve
37	Checking Valve Assembly
38	O Ring, Valve Cap
39	Checking Valve Cap
40	Outlet Plug, Manifold

41	Thermal Relief Valve
42	Washer
43	Bolt, Manifold
44	Screw, Knob Cap
45	Plastic Knob Cap
46	Pressure Adjusting Knob
47	Upper Seat, Adjusting Spring
48	Pressure Adjusting Spring
49	Spring Seat
50	Screw, Jam Nut
51	Pressure Jam Nut
52	Unloader Valve Assembly
53	Valve Seat
54	O Ring, Valve Seat
55	Gasket, Unloader Valve Housing
56	Detergent Injector Fitting
57	O Ring, Injector Fitting
58	Ball Bearing, Injector Fitting
59	Spring, Injector Fitting
60	Plug, Easy Start
61	O Ring, Plug, Easy Start
62	Valve Core, Easy Start
63	O Ring, Valve Core, Easy Start
64	Spring, Easy Start
65	Water Outlet Banjo Bolt
66	O Ring, Outlet Banjo Bolt
67	O Ring, Unloader Valve Housing
68	Unloader Valve Housing
69	O Ring, Outlet Checking Valve
70	Outlet Checking Valve
71	Spring, Outlet Checking Valve
72	O Ring, Outlet Fitting
73	Quick Disconnect Outlet Fitting
74	Gasket, Bypass Housing
75	Water Inlet Banjo Bolt
76	O Ring, Inlet Banjo Bolt
77	Bypass Housing
78	Swivel Nut, Inlet Connector
79	Body, Inlet Connector
80	Filter Washer, Inlet Connector

EXPLODED DIAGRAM & PARTS LIST- FRAME

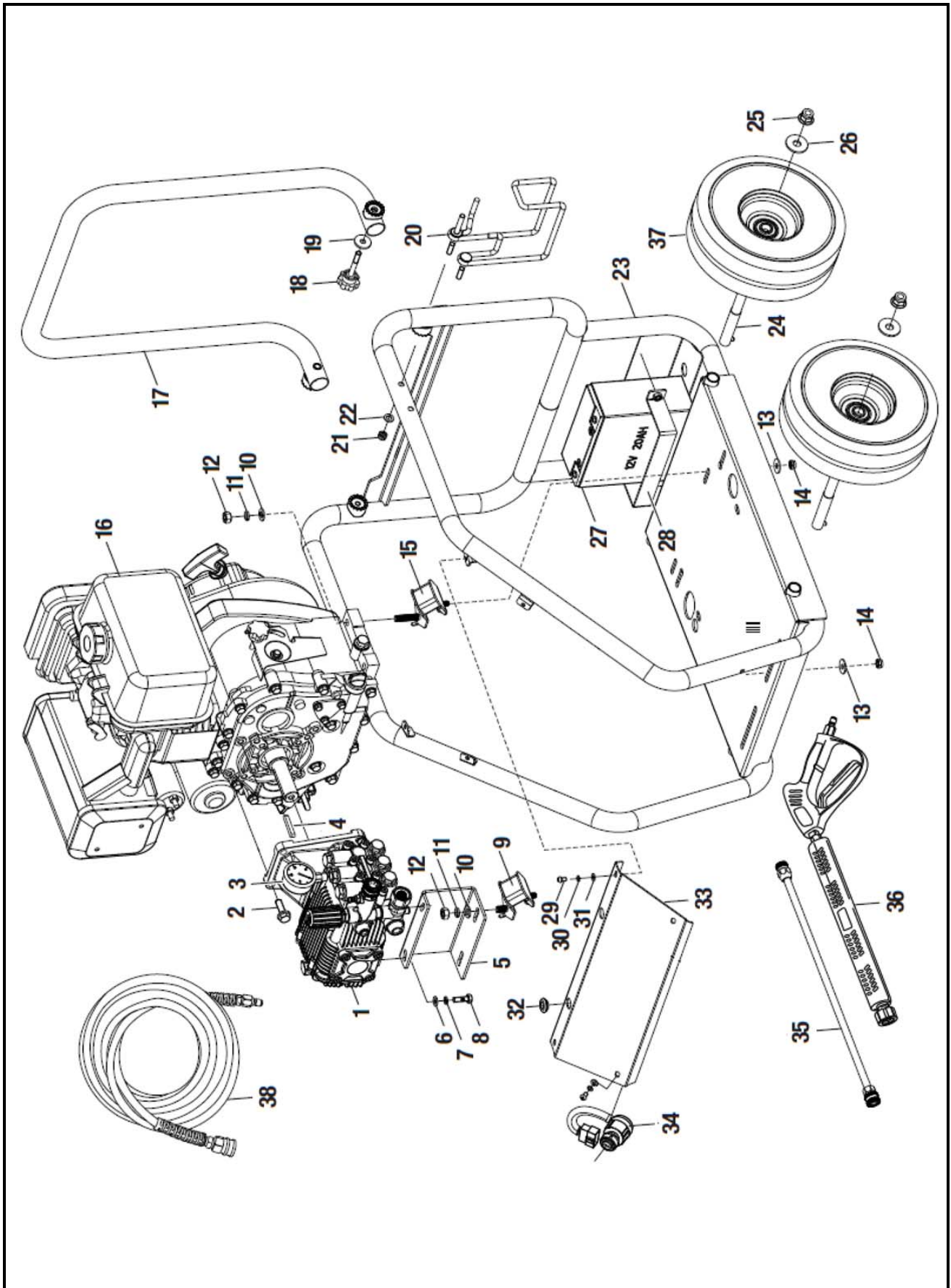

1	Pump
2	Bolt
3	Pressure Gauge (Not Fitted on This Model)
4	Key
5	Anti Vibration Holder
6	Plain Washer
7	Spring Washer
8	Bolt
9	Rubber Feet (Pump)
10	Plain Washer
11	Spring Washer
12	Screw Nut
13	Plain Washer
14	Screw Nut
15	Rubber Feet (Engine)
16	Engine
17	Handle
18	Handwheel Bolt
19	Plain Washer
20	Hose & Lance Storage Bracket

21	Screw Nut
22	Plain Washer
23	Frame Body
24	Axle
25	Wheel Fix Lock Nut
26	Plain Washer
27	Battery
28	Case
29	Bolt
30	Spring Washer
31	Plain Washer
32	Grommet
33	Frame Face Plate
34	Key Start
35	Wand/Lance
36	Gun
37	Wheel
38	High Pressure Hose

A SELECTION FROM THE VAST RANGE OF

Clarke®

QUALITY PRODUCTS



AIR COMPRESSORS
From DIY to industrial, Plus air tools, spray guns and accessories.

GENERATORS
Prime duty or emergency standby for business, home and leisure.

POWER WASHERS
Hot and cold, electric and engine driven - we have what you need

WELDERS

Mig, Arc, Tig and Spot.
From DIY to auto/industrial.

METALWORKING
Drills, grinders and saws for DIY and professional use.

WOODWORKING
Saws, sanders, lathes, mortisers and dust extraction.

HYDRAULICS
Cranes, body repair kits, transmission jacks for all types of workshop use.

WATER PUMPS
Submersible, electric and engine driven for DIY, agriculture and industry.

POWERTOOLS
Angle grinders, cordless drill sets, saws and sanders.

STARTERS/CHARGERS
All sizes for car and commercial use.



PARTS & SERVICE: 0208 988 7400

Parts Enquiries
Parts@clarkeinternational.com

Servicing & Technical Enquiries
Service@clarkeinternational.com

SALES: UK 01992 565333 or Export 00 44 (0)1992 565335

Clarke® INTERNATIONAL Hemnall Street, Epping, Essex CM16 4LG
www.clarkeinternational.com